

FIXED LITE WINDOW



ACOUSTIC SERIES - Rw41 (215mm overall depth)

Rylock's Acoustic Series Fixed Lite Windows are designed to help minimise the entry of intrusive noise into your home. Tested for performance by CSIRO, these windows employ a series of secondary glazing panels behind fixed windows derived from the AA Series

By spacing the secondary glazing away from the exterior frame, a gap between glass panes of around 100mm is created. In comparison to double glazing for thermal benefits, acoustic double glazing requires a much larger gap between glass panes

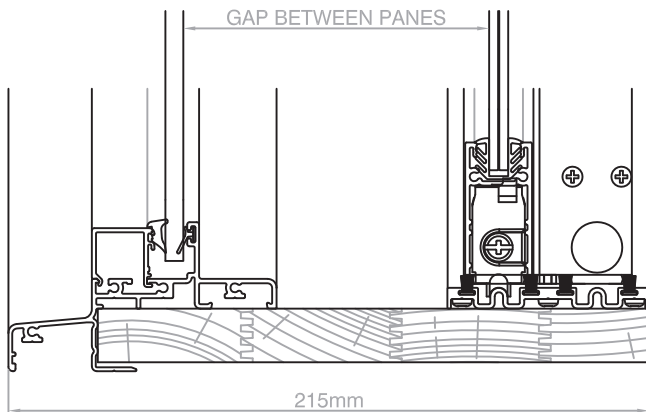

After-market or retro-fit systems often look like an obvious addition to the existing window. Acoustic Series products integrate both primary & secondary window elements inside the one reveal box, making for an attractive solution for noise attenuation

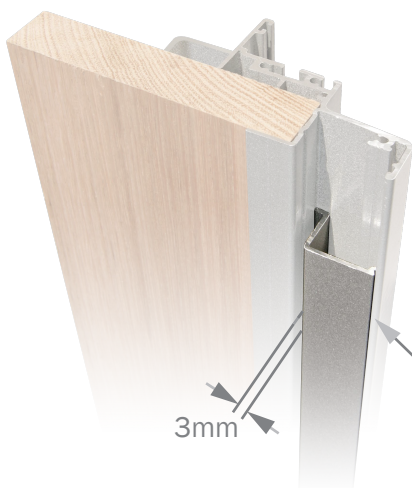

The optional external frame infill has a 15 x 3mm slot for flashing insertion (illustrated for clarity without secondary glazing)

FIXED LITE WINDOW



ACOUSTIC SERIES - Rw41 (215mm overall depth)

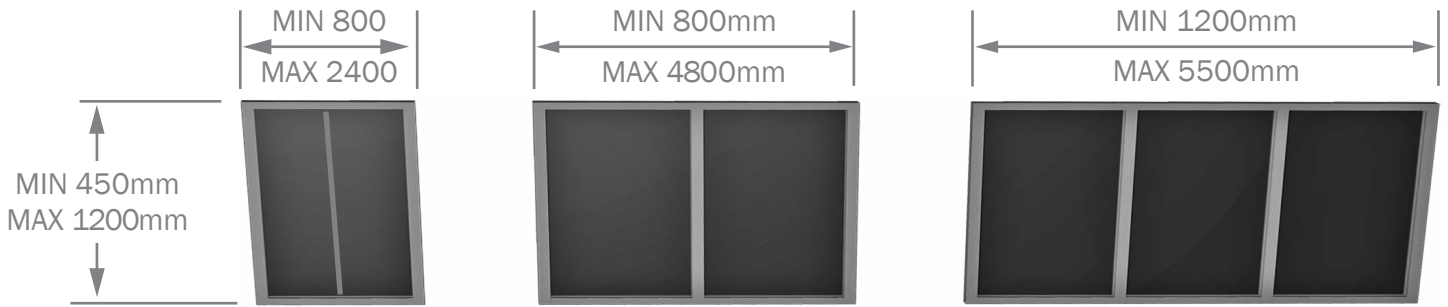

UP TO 1200mm HIGH: FOR 1 & 2 PANEL WINDOWS A MAXIMUM HEIGHT-WIDTH (PANEL) RATIO of **3:2** MUST BE ADHERED TO, WHILST THE 3 PANEL WINDOW HEIGHT-WIDTH (PANEL) RATIO IS **1:1** MAXIMUM

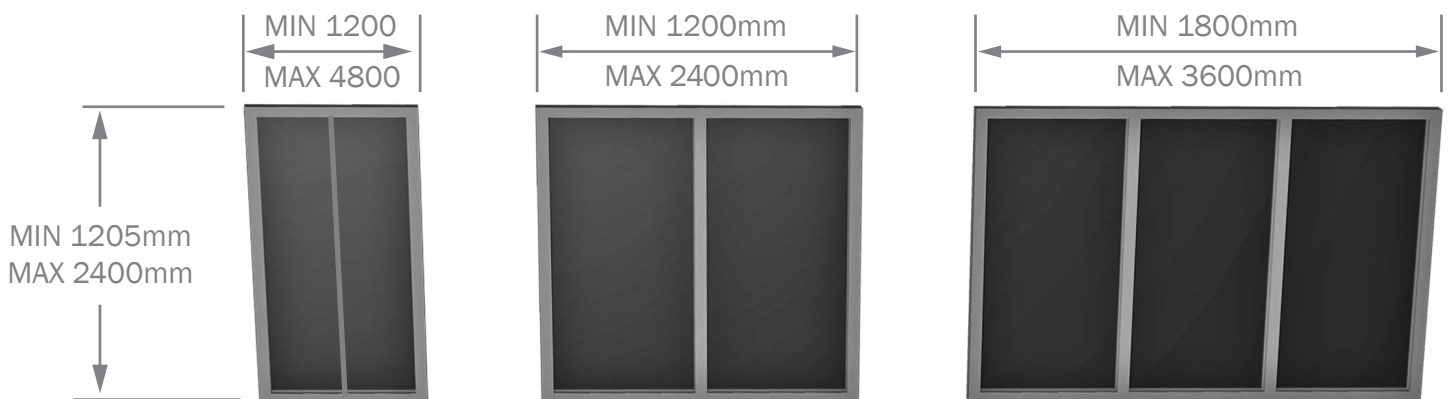

OVER 1200mm HIGH: FOR 1 & 2 PANEL WINDOWS A MAXIMUM HEIGHT-WIDTH (PANEL) RATIO of **2:1** MUST BE ADHERED TO, WHILST THE 3 PANEL WINDOW HEIGHT-WIDTH (PANEL) RATIO IS **4:3** MAXIMUM

NOTE: ALL SIZES ARE TYPICAL RATHER THAN DEFINITIVE. FOR OTHER SIZES, DISCUSS WITH YOUR SALES CONSULTANT
SINGLE PANEL WINDOWS WILL BE 'SPLIT' VERTICALLY BY THE SECONDARY GLAZING FRAME (IN THE CENTRE)

Sizing

Window style & opening detail should be considered as viewed externally

Sizes indicated are the overall window size. Reveal is inline with outer frame dimension

For Stud openings add 20mm to both height & width

Glazing

Glazing strength to minimum N3 rating. External glazing is 6mm, internal (secondary) glazing is 6.38mm laminated

Performance

Performance Index Number Rw: 41

Certification

Certified performance data (from CSIRO) for Rw, STC & Rw+CTR are available on request

Specify

Frame colour, configuration, height, width & overall depth (minimum 215mm due to acoustic spacing between panes)

Optional: external frame infill, sill flap, external glass type

The above product sizes comply with structural requirements (AS2047-2014, *Windows and external glazed doors in buildings*) for an 'N1' wind rating (AS4055-2012, *Wind loads for housing*).

This is typical of sites in suburban areas. In addition, the location has a Terrain Category of 3, is Topographic Class 1 or 2 and assumes the building will be surrounded by others of similar size.

Please specify if your site has different characteristics to any of those listed. Your building professional (architect, designer, surveyor, engineer, builder, etc.) can often assist with such determinations.