

FIXED LITE WINDOW

AA SERIES - 65mm FRAME



Transoms (horizontal) or mullions (vertical) may be fitted within a single outer frame

Mitred corners enhance the window's clean appearance. All fixings are made from durable stainless steel

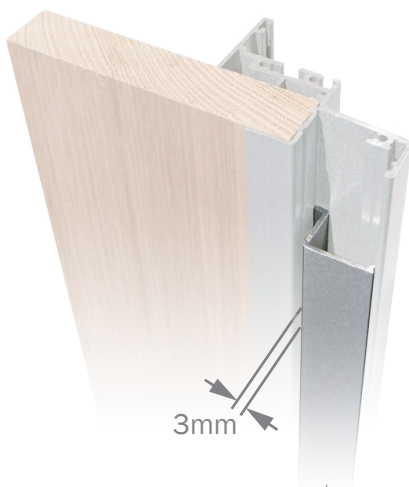

The optional external frame infill has a 15 x 3mm slot for flashing insertion

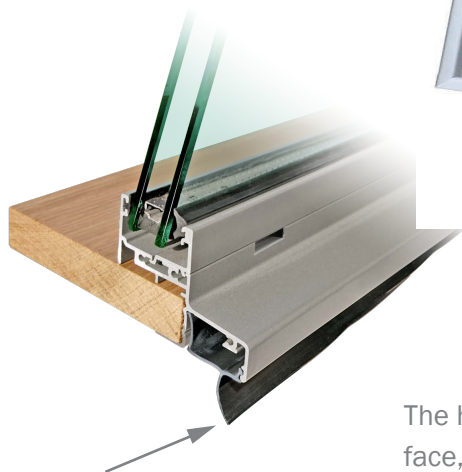

All glass is installed into dual vinyl sided rebates, ensuring vibration free glazing. A co-extruded santoprene inner seal resists shrinkage & also assists with weatherproofing

The hardwood reveal sits inline with the frame's outer face, simplifying installation into a variety of wall types

An optional sill flap may be specified when required. Hardwood reveals can be supplied as primed or raw, or with a 1.6mm spacer to assist in the creation of a 'square set' look

FIXED LITE WINDOW



AA SERIES - 65mm FRAME

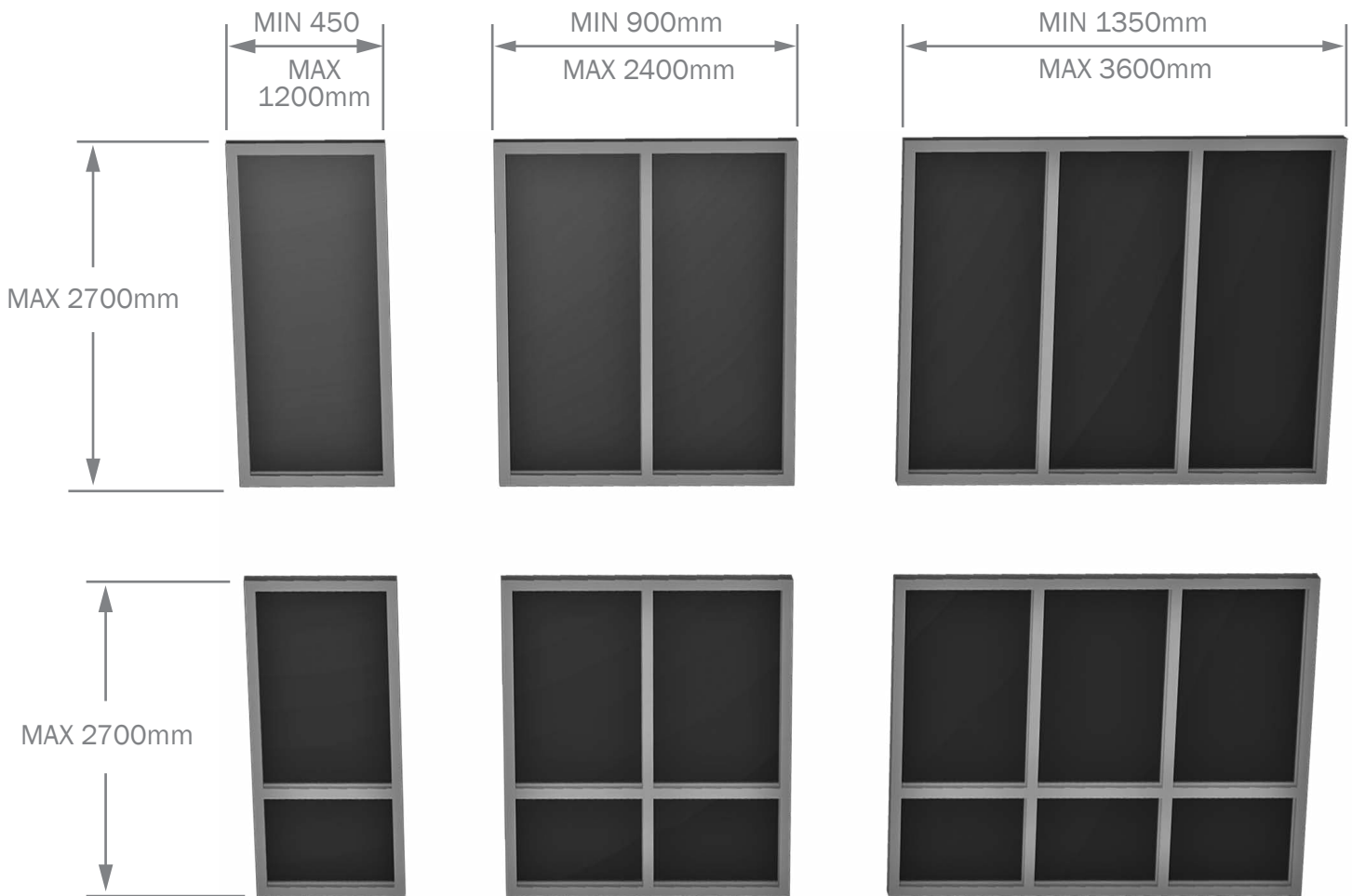

NOTE: ALL SIZES ARE TYPICAL RATHER THAN DEFINITIVE. FOR SIZES OUTSIDE OF THESE (incl. raked windows) PLEASE DISCUSS WITH YOUR RYLOCK SALES CONSULTANT

Sizing

Window style & opening detail should be considered as viewed externally
Sizes indicated are the overall window size. Reveal is inline with outer frame dimension
For Stud openings add 20mm to both height & width

Glazing

Glazing strength to minimum N3 rating, maximum double glazed panel thickness is 22.38mm

Certification

Certified performance data including WERS ratings are available for this product on request

Specify

Frame colour, configuration, height, width & overall depth, reveal type (including for plaster reveals)
Optional: external frame infill, reveal equaliser, sill flap, glass type

The above product sizes comply with structural requirements (AS2047-2014, *Windows and external glazed doors in buildings*) for an 'N1' wind rating (AS4055-2012, *Wind loads for housing*).

This is typical of sites in suburban areas. In addition, the location has a Terrain Category of 3, is Topographic Class 1 or 2 and assumes the building will be surrounded by others of similar size.

Please specify if your site has different characteristics to any of those listed. Your building professional (architect, designer, surveyor, engineer, builder, etc.) can often assist with such determinations.

FIXED LITE WINDOW



AA SERIES - 90mm FRAME

The 90mm Fixed Lite couples neatly to all AA Series 90mm frame windows - hinged, sliding & counter balanced double-hung. These windows can also couple to 125mm doors & windows, where a 35mm 'step' to the interior equalises the differing frame depths. 90mm Fixed windows are not available as raked (angled) units, however the 65mm & 125mm versions adequately cater for these styles.

Mitred corners enhance the window's clean appearance.

All fixings are made from durable stainless steel

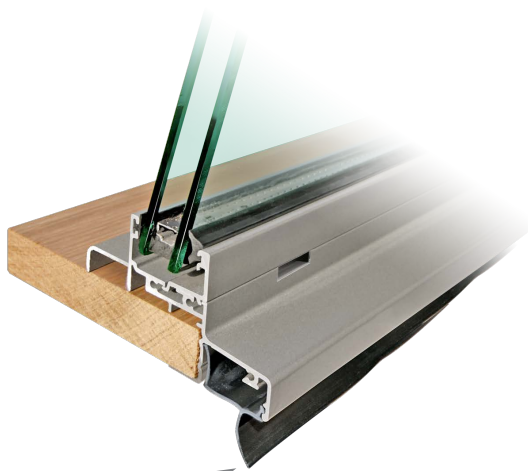

An optional sill flap may be specified when required. Hardwood reveals can be supplied as primed or raw

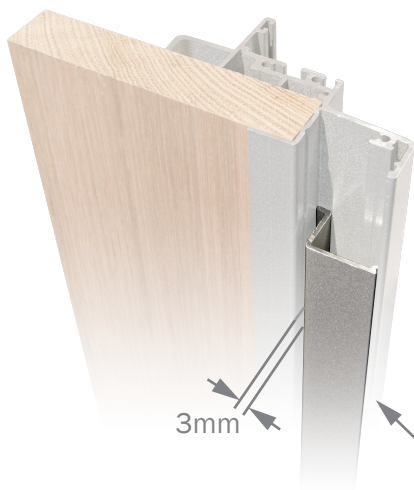

All glass is installed into dual vinyl sided rebates, ensuring vibration free glazing. A co-extruded santoprene inner seal resists shrinkage & also assists with weatherproofing

The hardwood reveal sits inline with the frame's outer face, simplifying installation into a variety of wall types. The reveal can be replaced with an aluminium section - or 'reveal equaliser' - however installation must also be considered, as this option can make it more difficult, & may necessitate back-fixing or similar

The optional external frame infill has a 15 x 3mm slot for flashing insertion

FIXED LITE WINDOW



AA SERIES - 90mm FRAME

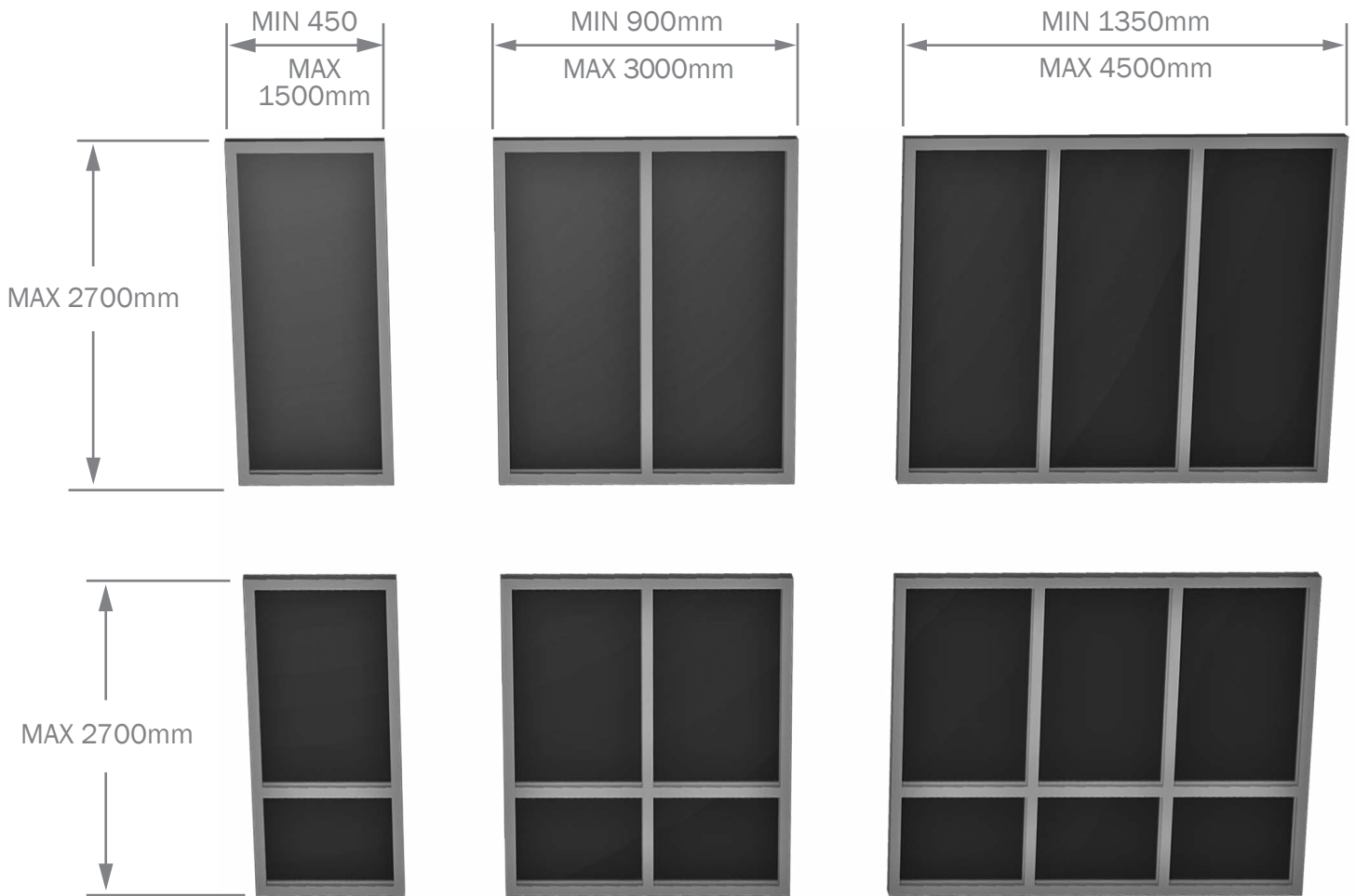

NOTE: ALL SIZES ARE TYPICAL RATHER THAN DEFINITIVE.
FOR SIZES OUTSIDE OF THESE PLEASE DISCUSS WITH
YOUR RYLOCK SALES CONSULTANT

Sizing

Window style & opening detail should be considered as viewed externally
Sizes indicated are the overall window size. Reveal is inline with outer frame dimension
For Stud openings add 20mm to both height & width

Glazing

Glazing strength to minimum N3 rating, maximum double glazed panel thickness is 22.38mm

Certification

Certified performance data including WERS ratings are available for this product on request

Specify

Frame colour, configuration (no raked units), height, width & overall depth, reveal type (including for plaster reveals)
Optional: external frame infill, reveal equaliser, sill flap, glass type

The above product sizes comply with structural requirements (AS2047-2014, *Windows and external glazed doors in buildings*) for an 'N1' wind rating (AS4055-2012, *Wind loads for housing*).

This is typical of sites in suburban areas. In addition, the location has a Terrain Category of 3, is Topographic Class 1 or 2 and assumes the building will be surrounded by others of similar size.

Please specify if your site has different characteristics to any of those listed. Your building professional (architect, designer, surveyor, engineer, builder, etc.) can often assist with such determinations.

SUPERLITE WINDOW



AA SERIES - 125mm FRAME

The SuperLite framing system caters primarily for large fixed windows. This 125mm deep frame also accommodates awning or casements sashes for ventilation & couples neatly with hinged doors, sliding doors & 90mm frame windows



The hardwood reveal sits inline with the frame's outer face. The reveal can be covered with an aluminium section - or 'reveal equaliser' - for a more commercial finish

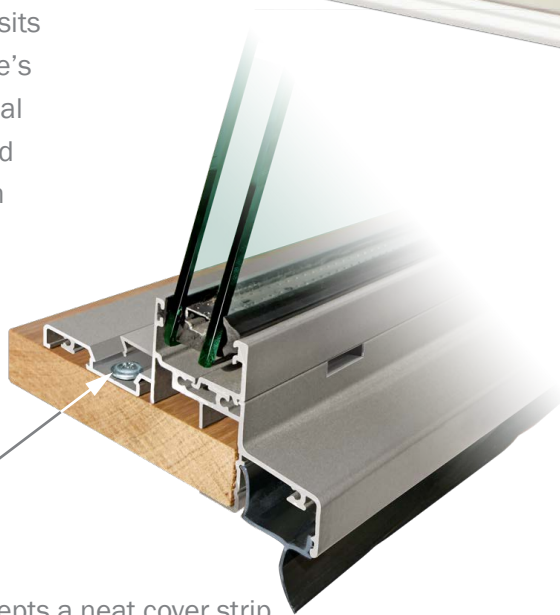

Mitred corners enhance the clean appearance of the window. All fixings are made from durable stainless steel

All glass is installed into dual vinyl sided rebates, ensuring vibration free glazing. A co-extruded santoprene inner seal resists shrinkage & also assists with weatherproofing

A fixing pocket that accepts a neat cover strip means SuperLite frames are both easy to install and suited to a wide variety of walling types.

An optional sill infill aligns the internal height of the sill with that of sliding, stacker & open-out hinged doors

MAX LITE

AA SERIES - 125mm FRAME



The Max Lite has one simple purpose - to fulfil the requirements of the largest, single-panel double glazed window

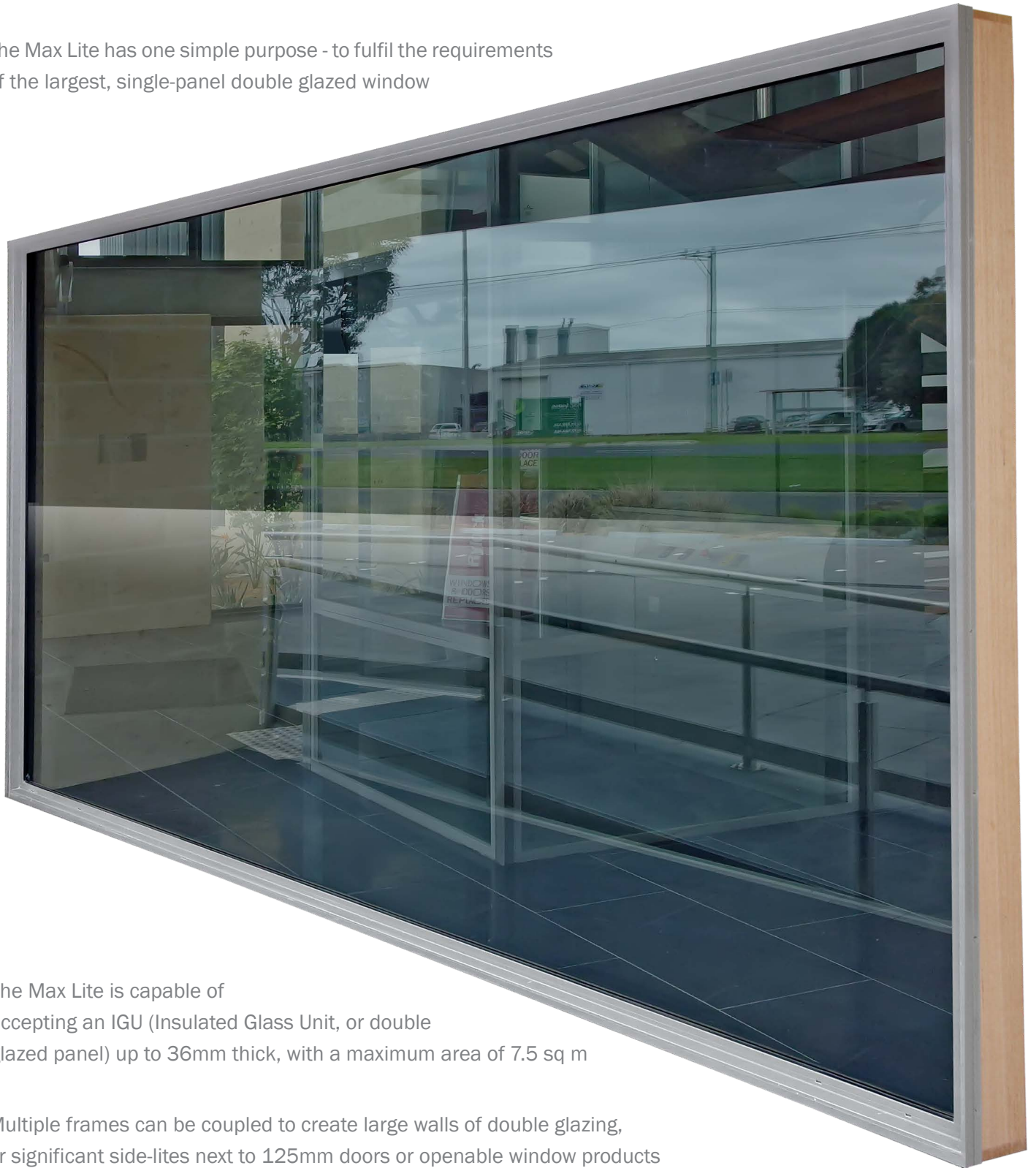

The Max Lite is capable of accepting an IGU (Insulated Glass Unit, or double glazed panel) up to 36mm thick, with a maximum area of 7.5 sq m

Multiple frames can be coupled to create large walls of double glazing, or significant side-lites next to 125mm doors or openable window products

A fixing pocket to the inside accepts a neat cover strip post-installation. Like most AA Series products, reveals are available in primed or raw hardwood, or for a 'commercial' look with a Reveal Equaliser (in coated aluminium)

All glass is installed into dual vinyl sided rebates, ensuring vibration free glazing. A co-extruded santoprene inner seal resists shrinkage & also assists with weatherproofing

MAX LITE

AA SERIES - 125mm FRAME

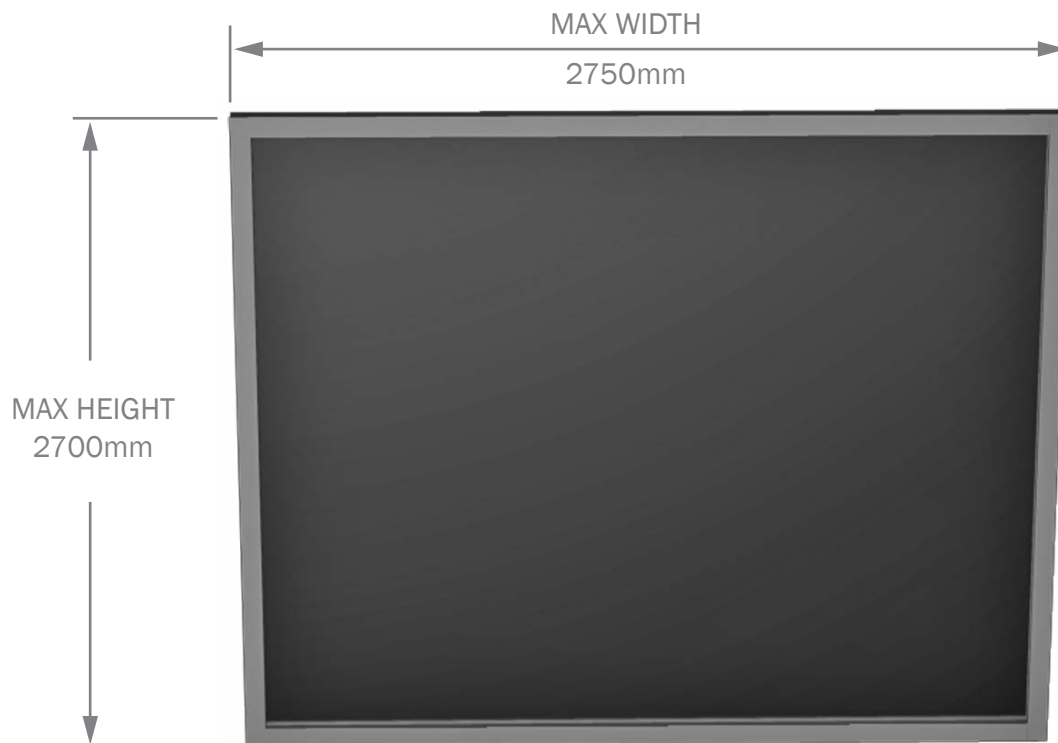

DOUBLE GLAZED SIZES

NOTE THAT HEIGHT & WIDTH MAY BE VARIED AS LONG AS TOTAL AREA REMAINS THE SAME (MAXIMUM OF 7.5 SQUARE METRES), SUBJECT TO RESTRICTIONS ON HEIGHT vs. WIDTH RATIO

NOTE: ALL SIZES ARE TYPICAL RATHER THAN DEFINITIVE. FOR SIZES OUTSIDE THESE - INCLUDING MULTIPLE, COUPLED UNITS - PLEASE DISCUSS WITH YOUR RYLOCK SALES CONSULTANT

Sizing

Window style & opening detail should be considered as viewed externally. Sizes indicated are the overall window size. Reveal is in line with outer frame dimension. For Stud openings add 20mm to both height & width

Glazing

Glazing strength to minimum N3 rating, maximum double glazed panel thickness is 36mm. Double glazed panels typically contain 8mm toughened glass, 16mm spacer, 8mm toughened glass

Certification

Certified performance data including WERS ratings are available for this product on request

Specify

Frame colour, height, width & overall depth, reveal type (including for plaster reveals)
Optional: external frame infill, reveal equaliser, sub sill, sill flap, glass type

The above product sizes comply with structural requirements (AS2047-2014, *Windows and external glazed doors in buildings*) for an 'N1' wind rating (AS4055-2012, *Wind loads for housing*).

This is typical of sites in suburban areas. In addition, the location has a Terrain Category of 3, is Topographic Class 1 or 2 and assumes the building will be surrounded by others of similar size.

Please specify if your site has different characteristics to any of those listed. Your building professional (architect, designer, surveyor, engineer, builder, etc.) can often assist with such determinations.

SUPERLITE WINDOW



AA SERIES - 125mm FRAME

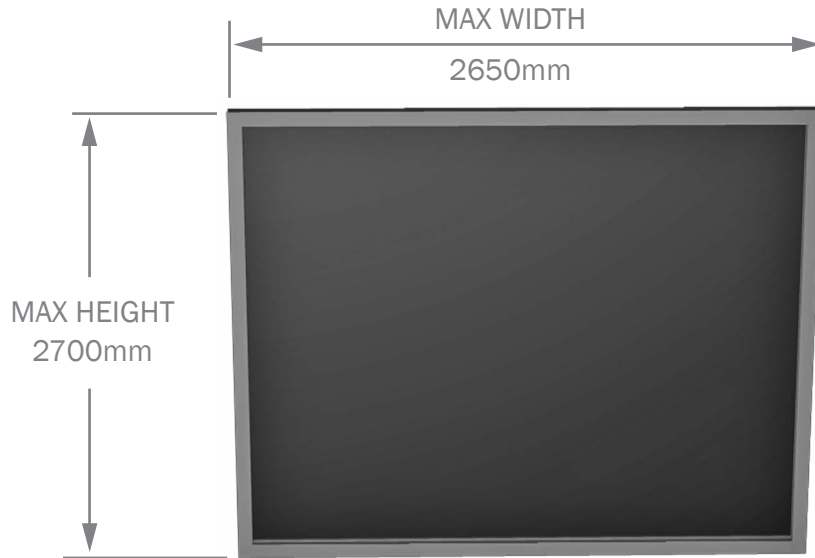

SINGLE GLAZED SIZES

NOTE THAT HEIGHT & WIDTH MAY BE CHANGED, AS LONG AS MAXIMUM AREA IS 7.2 SQUARE METRES. LIMITATIONS ALSO EXIST FOR MAXIMUM HEIGHT & WIDTH

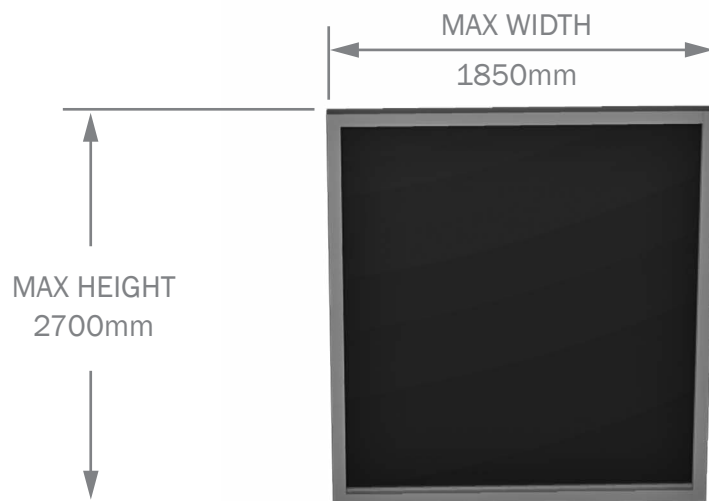

DOUBLE GLAZED SIZES

NOTE THAT HEIGHT & WIDTH MAY BE CHANGED, AS LONG AS MAXIMUM AREA IS 5 SQUARE METRES. LIMITATIONS ALSO EXIST FOR MAXIMUM HEIGHT & WIDTH

NOTE: ALL SIZES ARE TYPICAL RATHER THAN DEFINITIVE. FOR SIZES OUTSIDE THESE - INCLUDING RAKES OR MULTIPLE, COUPLED UNITS - PLEASE DISCUSS WITH YOUR RYLOCK SALES CONSULTANT

Sizing

Window style & opening detail should be considered as viewed externally. Sizes indicated are the overall window size. Reveal is inline with outer frame dimension. For Stud openings add 20mm to both height & width

Glazing

Glazing strength to minimum N3 rating, maximum double glazed panel thickness is 22.38mm

Double glazed versions typically use a toughened 6/10/6mm panel, whilst single glazing is typically in 10mm toughened glass

Certification

Certified performance data including WERS ratings are available for this product on request

Specify

Frame colour, configuration, height, width & overall depth, reveal type (including for plaster reveals)

Optional: external frame infill, reveal equaliser, sill align infill (single panel only), sill flap, glass type

The above product sizes comply with structural requirements (AS2047-2014, Windows and external glazed doors in buildings) for an 'N1' wind rating (AS4055-2012, Wind loads for housing).

This is typical of sites in suburban areas. In addition, the location has a Terrain Category of 3, is Topographic Class 1 or 2 and assumes the building will be surrounded by others of similar size.

Please specify if your site has different characteristics to any of those listed. Your building professional (architect, designer, surveyor, engineer, builder, etc.) can often assist with such determinations.